

MINIBIKE

***Elite* 14 - R**

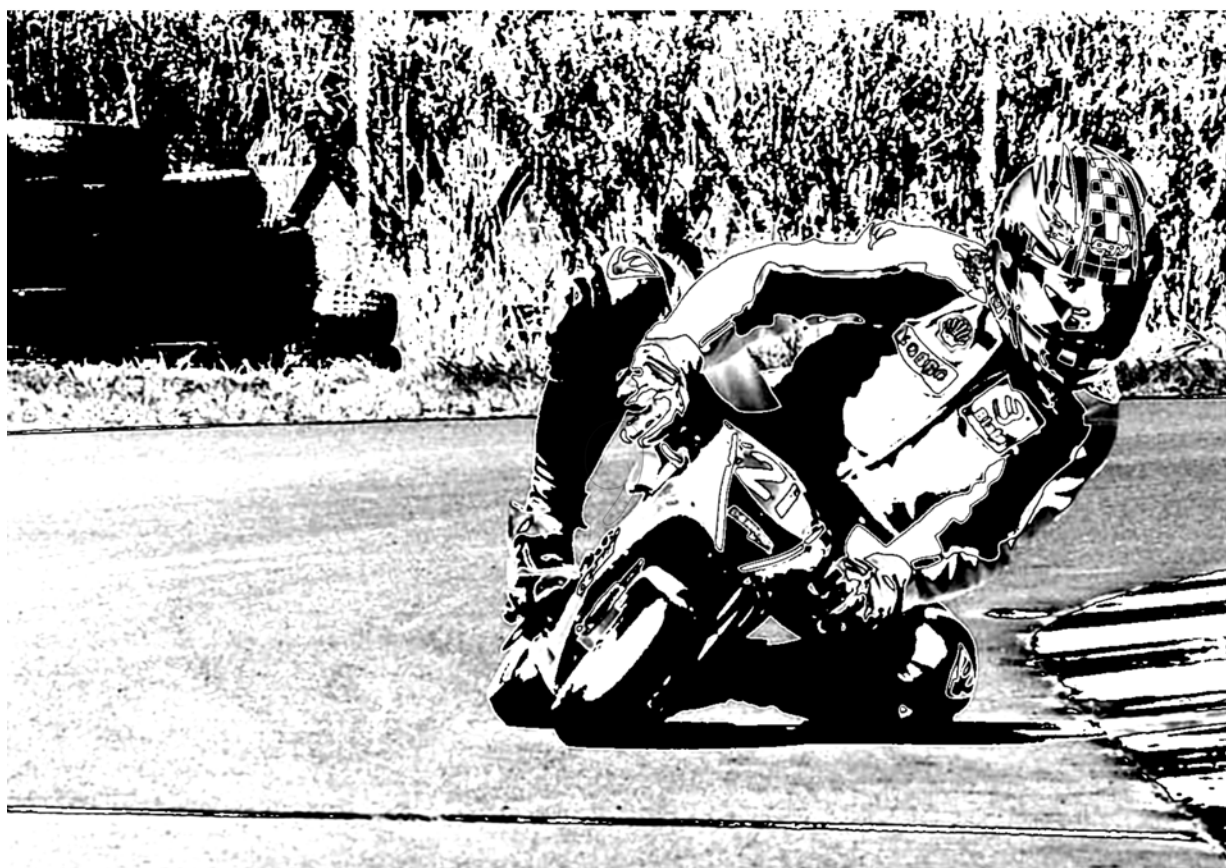

Blata[®]

CE



EC Declaration Of Conformity

Manufacturer: Blata, s r.o.
Address: Prazska 9
678 01, Blansko
Czech Republic

Product: Minibike
Model: Elite 14
Derived types: Elite 14 - WRS
Elite 14 - WR
Elite 14 - R
Elite 14 - JRacing
Elite 14 - 4,2

The undersigned hereby declares, on behalf of BLATA s.r.o., that the above-referenced product, to which this declaration relates, is in conformity with the provisions of:

Council Directive 98/37/EC of 22 June 1998 on the approximation of the laws of the Member States relating to machinery and its amending directives

Council Directive 89/336/EEC of 3 May 1989 on the approximation of the laws of the Member States relating to Electromagnetic Compatibility (EMC) and its amending directives

and that the product has been designed to comply with the relevant sections of the below referenced specifications:

ČSN EN ISO 12100-1:2004 (EN ISO 12100-1:2003)
ČSN EN ISO 12100-2:2004 (EN ISO 12100-2:2003)
ČSN EN 294:1993 (EN 294:1992)
ČSN EN 811:1998 (EN 811:1996)
ČSN EN 953:1998 (EN 953:1997)
ČSN EN 563:1996 including amendment A1:2000 (EN 563:1994)
ČSN EN 1050:2001 (EN 1050:1996)
ČSN EN 55 012:2002
ČSN EN ISO 3744:1995
ČSN EN ISO 11202:1997

BLANSKO 6-1-04-2006



Pavel Blata
Managing Director

Noise emitted by machinery and equipment (Minibike BLATA ELITE 14) - Measurement of emission sound pressure levels at a work station and at other specified positions. Levels measured by authorized person (TUV CZ s.r.o.). Test record (no. : 814/90/06/BT/IZ/H) is deposited with producer.

RPM	Average level of the acoustic pressure A at a work station (ČSN EN ISO 11202)	Total average level of the acoustic power (ČSN EN ISO 3744)
2600 rpm (idling speed)	$L_{Aeq} = 82,8 \text{ dB}$	$L_{WA} [\text{dB (A)}] = 87,2 \text{ dB}$
11 000 rpm	$L_{Aeq} = 106,8 \text{ dB}$	$L_{WA} [\text{dB (A)}] = 112,9 \text{ dB}$



SAFETY WARNING

Always pay attention to the instructions and safety warnings below

This manual contains important safety information and instructions which should be read carefully before operating the vehicle. For your own safety and the safety of others follow these rules.

Neither manufacturer nor distributor is responsible for injuries caused by unsafe and improper use of the vehicle.



This vehicle is not allowed to be used on public roads!



Unsafe and careless use of the vehicle can result in serious injuries. The driver can minimize the potential risks by wearing safety equipment. The driver must wear a safety helmet, goggles, gloves, elbow pads, kneepads, and firm footwear. Avoid rough surfaces and obstacles. Always drive with both hands on the handlebars.



Always inspect the bike before each ride (refer to the article 'INSPECTION AND MAINTENANCE'). Failure to inspect and maintain your bike properly increases the risk of an accident or damage to the vehicle.



Fuel and fuel vapour are highly toxic and flammable. Always be careful when handling fuel – it can burn or poison you.

- stop the engine and turn off the fuel tap, keep naked flames and sparks away from your bike.
- do not smoke near your bike.
- refuel only outdoors in a well ventilated space
- clean up any excess fuel immediately
- keep children and pets away



Always ride within the limits of vehicle/ rider and weather conditions to avoid unnecessary accidents and injuries.



Check-ups
Shut the engine off when performing maintenance check-ups otherwise You could be severely injured if your hands or clothing get caught by moving parts.



Make sure the engine and exhaust are cold before performing any inspection of this machine



Riding with a chain in poor condition or improperly adjusted can lead to serious injury. Always, Inspect, Adjust and Maintain the drive chain properly before each ride.



Failure to inspect and properly maintain the brakes increases the risk of having an accident. Before each ride check the brake cables and the brakes efficiency.



Riding with worn brake pads can reduce the braking performance and cause an accident. Check and replace brake pads according to the instructions in this manual.



Using worn, improperly inflated, or incorrect tyres will reduce stability and can cause an accident.

DISPOSAL OF UNUSABLE PRODUCT

Unusable product become a waste and it's desposal should be in accordance with the law and any applicable local regulations. Don't throw this product to municipal waste.

MINIBIKE - ELITE 14 R

SERVICE MANUAL FOR USE AND MAINTENANCE AND SPARE PARTS LIST

For your own safety and the safety of others Follow these recommendations in order to use your MINIBIKE safely and correctly. Read the instructions CAREFULLY, failure to do so may place yourself and others in extreme and or ultimate DANGER. If you do not understand the instructions and Data then, you are not to attempt to operate this Minibike under any circumstances. It may be used for show purposes only!

CONTENTS

	PAGE
INTRODUCTION	2
TECHNICAL DATA	2
UNPACKING AND SETTING UP BEFORE RIDING	3
SAFETY	3
BEFORE STARTING.....	3
STARTING THE ENGINE - FIG. 2	4
CARBURETOR - FIG. 3	4
RIDING	4
PERIODIC MAINTENANCE	5
CHAIN SETTING AND MAINTENANCE	5
CENTRIFUGAL CLUTCH REPAIR OR REPLACEMENT	5
BRAKES ADJUSTING - FIG. 4.....	6
FRONT BRAKES PADS REPLACEMENT	6
REAR BRAKES PADS REPLACEMENT	6
MINIBIKE ELITE 14 R - FIG. 5.....	7,8
PARTS LIST	9,10
ENGINE BLATA – FIG. 10	11
CLUTCH COMPLETE - FIG. 6	12
FRONT AND REAR BRAKES - FIG. 7	13
REMOVE AND REFIT THE FRONT WHEEL.....	14
REMOVE AND REFIT THE REAR WHEEL.....	14
REPLACEMENT OF SPROCKET - FIG. 9	14
REPLACEMENT OF TIRE	15
REMOVE AND REFIT AIR FILTER	15
CLUTCH ADJUSTMENT – FIG. 8	15
TORQUE SETTINGS.....	16
STORAGE PROCEDURE	17

INTRODUCTION

The Minibike Elite 14 R is designed and built for use on a paved closed circuit track. The track should be clean and without obstacles of any kind. Qualified adults and younger persons can drive the minibike. Children can drive the minibike only under the supervision of a responsible adult person. The minibike is constructed especially for racing competitions on special racing tracks. Minibike Blata should not be used during winter season and under bad weather conditions. Usage under these conditions leads to abnormal mechanical wear and corrosion of most minibike parts - especially those directly exposed to climatic influences. Beside that, riding under these conditions increase the risk of injury or health damage.

The minibike uses a single-cylinder two-stroke, Gasoline combustion engine, and has an air filter and exhaust silencer. Transfer of power to the rear wheel is through a drive chain. The the overall drive ratio to the rear wheel can be changed by the replacement of chain sprockets. The front and rear wheel is equipped with disk brakes. The rear brake is controlled with the left lever and the front brake is controlled with the right lever on the handlebars.

BASIC TECHNICAL DATA

ENGINE:	BLATA	TWO-STROKE
	NUMBER OF CYLINDERS	1
	CYLINDER CAPACITY	39,8 cc
	ENGINE COOLING SYSTEM	AIR COOLED
	POWER OUTPUT	7,5 kW at 11 800 rpm
	TORQUE	7,2 Nm at 10 500 rpm
	CARBURETOR	PHVA 14 - DELL' ORTO
	FUEL ADMISION	REED VALVE DIRECT TO CRANKCASE
	IGNITION	CONTACT - LESS
	SPARK PLUG	NGK B9 EGV
	STARTING	HAND PULL TYPE, MANUAL
	CLUTCH	CENTRIFUGAL AUTOMATIC
FRAME:	WELDED	HIGH STRESS STEEL TUBES
BRAKES:	FRONT WHEEL	DISC BRAKES
	REAR WHEEL	DISC BRAKES
WHEELS:	FRONT	OF LIGHT ALLOY 2,1"x 6,5"- 90
	REAR	OF LIGHT ALLOY 2,3"x 6,5" - 130
TIRE:	FRONT	SIZE 90/65 - 6,5"
	REAR	110/50 - 6,5", 90/65 - 6,5"
FUEL:	MIXTURE OF PETROL 95 OR HIGHER OCTANE + 2T SYNTHETIC OIL	
	MIXING RATIO (after break in period)	33 : 1
	TANK CAPACITY	1 Litre
SPEED:	WITH THE INSTALLED RATIO:	up to 50mph(80km/h)
UNLOADED WEIGHT:	(49,28lbs.) 22,4 kg
CARRYING CAPACITY:	(240lbs) 110 kg
BASIC DIMENSIONS:		
	LENGTH	37,7 " (960 mm)
	WIDTH	20" (500mm)
	HEIGHT	21,2" (540 mm)

UNPACKING AND SETTING UP BEFORE RIDING

The minibike is delivered in a cardboard carton and packed with folded handlebars and brake levers. After unpacking, set up the handlebars into the position, that suits the best for driving. The maximum pulled brake lever position should not touch on the handlebar grip. After setting up, tighten the handlebar bolts 1, brake lever bolts 2, and the throttle assy. Bolts. See, Fig. 1. The level of foot rest's can be regulated by loosening the bolt M5 (914.003.01) on the handle of the foot rest (139.001.01). The foot rest can be moved to the front or back position. It is recommended to try and check the position of handlebars and foot rest's individually. While tightening the bolts and nuts, do not use an excessive force as to not damage the threads, or distort the tubes and other parts. Verify the smooth and perfect function of the Bowden cables to throttle and both brakes. Fill the fuel tank with fuel. (Gas-oil mix) Failure to use the proper oil mix ratio will result in Engine damage for which you will be responsible.

Fig. 1

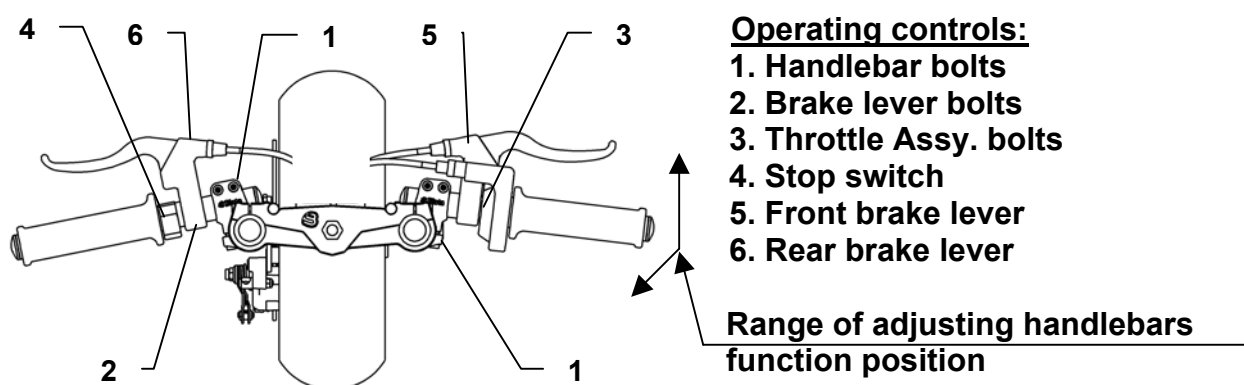

SAFETY

The minibike is unsuitable for public road use. It does not comply with valid Safety Standards. Unsafe and careless use of a minibike can result in serious injuries. The driver can minimize the potential risks by wearing the Safety Equipment. The driver must wear safety helmet, goggles, gloves, elbow pads, kneepads, and firm footwear. The minibike cannot be used on wet, icy or oily surfaces. Avoid uneven surfaces and obstacles. Drive with two hands on the handlebars.

BEFORE STARTING

It is strongly recommended to follow all the instructions about the break-in period to promote engine reliability and long life. Break-in period of the minibike is complete after the consumption of five full fuel tanks. It is important to use fuel mixture of petrol 95 or higher Octane with 2-stroke synthetic oil in the ratio 30:1 and after break-in period a ratio of 33 :1. Mix the petrol and oil completely before putting it into the fuel tank. During the break-in period do not run the engine at maximum RPM and do not allow the engine to overheat.

Check the tire inflation – 200 kPa (2 bars) or (28 to 30psi) to be commensurate with the driver's weight. The Tyre pressure should never exceed 2,5 bars, (38psi) in either the front or rear wheel.

STARTING THE ENGINE

Engine starting should be done only on the stand - Fig. 2. Fill the fuel tank and close it with the filler cap. Open the Gas petcock. Set the petrol supply cock. Set the choke lever into position "C", Fig. 3. Without turning the accelerating handle, pull gently twice the starting wire and by next quick pull start the engine. It is not allowed to pull the starting wire up to full winding off. After a short engine run, set the choke lever back to position "A". Let the engine run about 1 min. Leave the minibike on the stand with running engine and if necessary adjust the revolutions so the rear wheel is not turning. For adjustment use the adjustment screw No. 3 on the carburetor Fig. 3.

Fig. 2

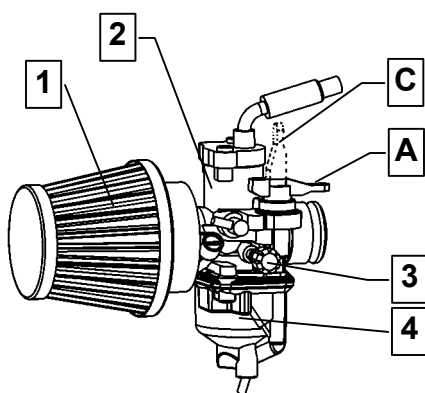
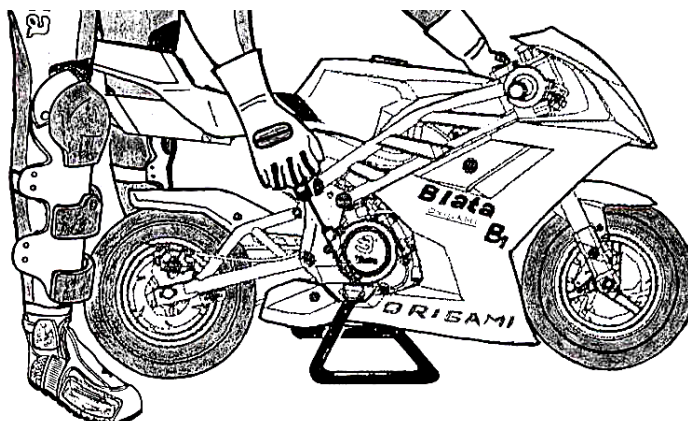

FIG. 3 CARBURETOR

1. Suction chamber
2. Carburetor body
3. Adjusting screw of no-load run
4. Float chamber

A – Cock position for riding
C – Cock position for cold starting

RIDING

Remove the minibike from the stand to sit on the seat. When seated, then slowly rotate the throttle grip to start riding. Before braking, rotate the Throttle grip to the off or idle position and lightly depress the rear brake lever with left hand and then the front brake lever with right hand. Beware to not skid the wheels. The minibike engine is switched off by pushing the red button (Engine stop switch) on the handlebars. It is necessary to check the tightness of bolts and nuts, especially of the engine, and the brake settings after the first ride and often during the break in period.

PERIODIC MAINTENANCE

Periodic maintenance is the best way to help the machine perform well, give longevity and provide safety and low cost operation. In addition, you will be spared from many worries from self caused problems, resulting from poor maintenance or no maintenance.

A - Before every ride:

1. Check the Cables and efficiency of brakes.
2. Check the lubrication and chain tension settings. The chain free play should be (5 mm) (.200in) After every ride clean the minibike carefully and keep it clean. Do not use aggressive cleaning detergents.
3. After 1-hour of use, wash the air filter in air drying spirits and lubricate it with special oil for air filters.
4. After 1- hour of use, check the state of the clutch pads. Review the clutch adjustment.

B. After every 5 hours of riding:

5. Check the tightness of all bolts and nuts. *Tighten with a properly adjusted torque wrench only ! For torque settings see tables on page 16.*
5. Wash the air filter in gas and lubricate it with special oil for an air filters to better catch the dust.
6. Clean carefully the carburetor float chamber.
7. Check the brake pads, the thickness of brake lining cannot be less than 1 mm (.039 in). Review the basic brake adjustment.
8. Check the state of the clutch pads - the thickness cannot be less than 1 mm (.039in). Review the clutch adjustment.

C - Every time after 10 hours of riding:

9. Check the state of the clutch pads - the thickness cannot be less than 1 mm (.039in).

CHAIN SETTING AND MAINTENANCE

To set the chain tension, loosen the Nut (920.011.01) of the axel thru the rear wheel and the nut (914.021.01) of the rear Caliper anchor plate. The required chain tension (chain free play) is (5 mm) (.200in) and is performed by equal movement of the Axle adjustor plate (153.033.00) on the both sides of the rear wheel. When the adjustment is correct, tighten the Axle nuts and the Caliper holding nut. Tighten the adjustor plate nuts both sides an extra nip, just to set them firmly. It is important to lubricate the chain regularly, to avoid excess wear and prolong effective lifetime. The lubrication is important after every ride on a wet surface. It is recommended to lubricate the minibike with special chain spray. If chain replacement is necessary, check both chain Sprockets and if there is a need to change them do it together with the chain.

CENTRIFUGAL CLUTCH PARTS, REPLACEMENT

Remove the chain guard by loosening two bolts M6 (916.020.01), Fig. 5. Loosen the chain and remove it from the sprocket. Next, loosen three bolts holding the aluminum clutch housing. Remove it together with steel clutch basket, and dismantle it. Loosen the bolt from the carrier and remove the clutch from the engine. Loosen and remove the adjustable bolts and springs. Then dismantle the safety rings from pins. When all this is done, replace with new clutch slipper shoes and springs (if required), at this time. During the reassembly process follow these steps: 1. put the plate with the springs on the slipper shoes. 2. Put the plate against the carrier and mount it on the fixed pins. Fit it with the safety rings and install the adjustable bolts.

ADJUSTING THE BRAKES

Small incremental brake adjustment

Free play at the handlebar lever is effected by turning the knurled end on the cable adjuster. This will allow the lever to be set at the nominal to ¼ inch of free lever movement.

Basic brake adjusting:

Screw in the knurled cable adjuster at the brake lever (122.002.00) so the cable is in it's most slack starting position.. At the caliper, loosen the nut, No. 3 and tighten the adjustable bolt No. 4, so the wheel cannot turn. Back off bolt No. 4 about ¼ to ½ of a turn and fix it with lock nut No. 3. Do not use the cable retainer No. 5 for adjusting the brakes!

Fig. 4

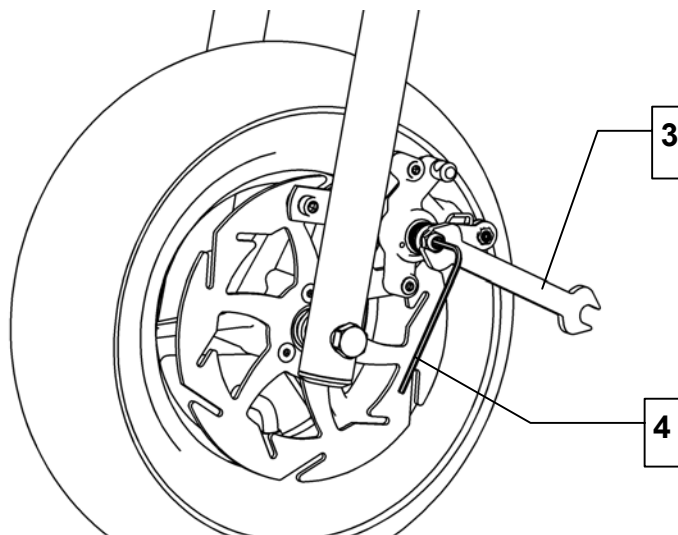

FRONT BRAKE PADS REPLACEMENT - FIG. 7

First screw in the knurled cable adjuster at the right brake lever (122.002.00) on the handlebars to the starting position (slackened cabled). Loosen the nut (332.020.00) and turn the adjustable bolt (916.065.02) in the way that by pressing the front brake lever, the lever (312.017.00) will be over the bolt head M5 (312.018.00), which protects brake pads and spring of pads (312.020.00). Unbolt this bolt and replace the old brake pads with new ones. When mounting the brake pads place the brake spring against both pads, so they are pressed into the front direction. While replacing the brake pads do not loosen bolts M5 (914.001.01) on the driving pins and do not loosen the cable retainer!

REAR BRAKE PADS REPLACEMENT - FIG. 7

First screw in the knurled cable adjuster at the left brake lever (122.001.00) on the handlebars to the starting position (slackended cable). Loosen the nut (320.020.00) and turn the adjustable bolt (916.065.02) all the way out. Unbolt the nut M10 (920.011.01) of the back axel, push it out and dismantle the rear wheel from the Swingarm. Push out the brake from driving pins, that will loosen the brake pads and replace the old ones at this time. While replacing the brake pads do not loosen bolts M5 (914.001.01) on the driving pins and do not loosen the cable retainer! During the mounting follow all these instructions in the reverse direction and then perform basic adjusting of the brakes.



Elite 14 - R

MINIBIKE

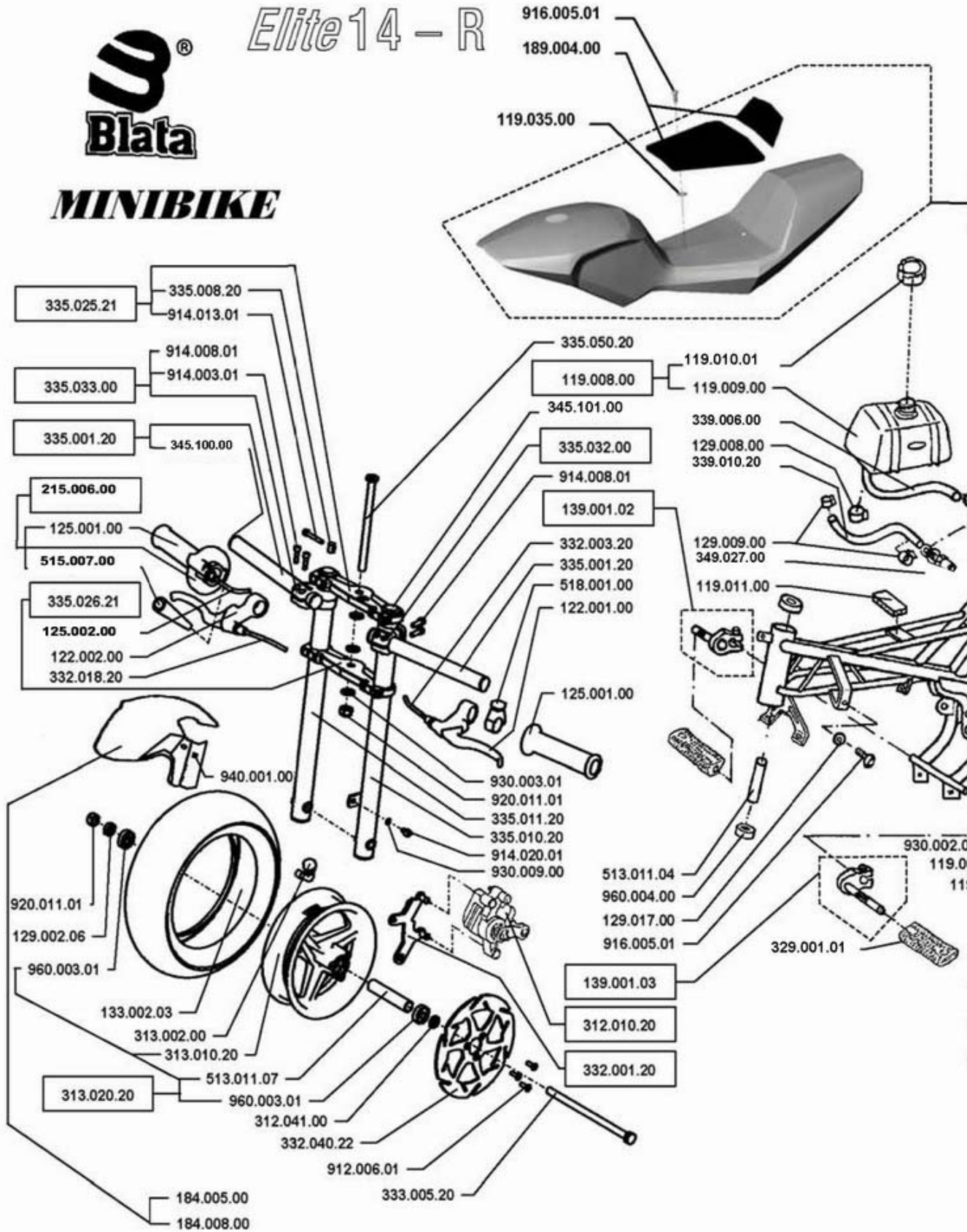

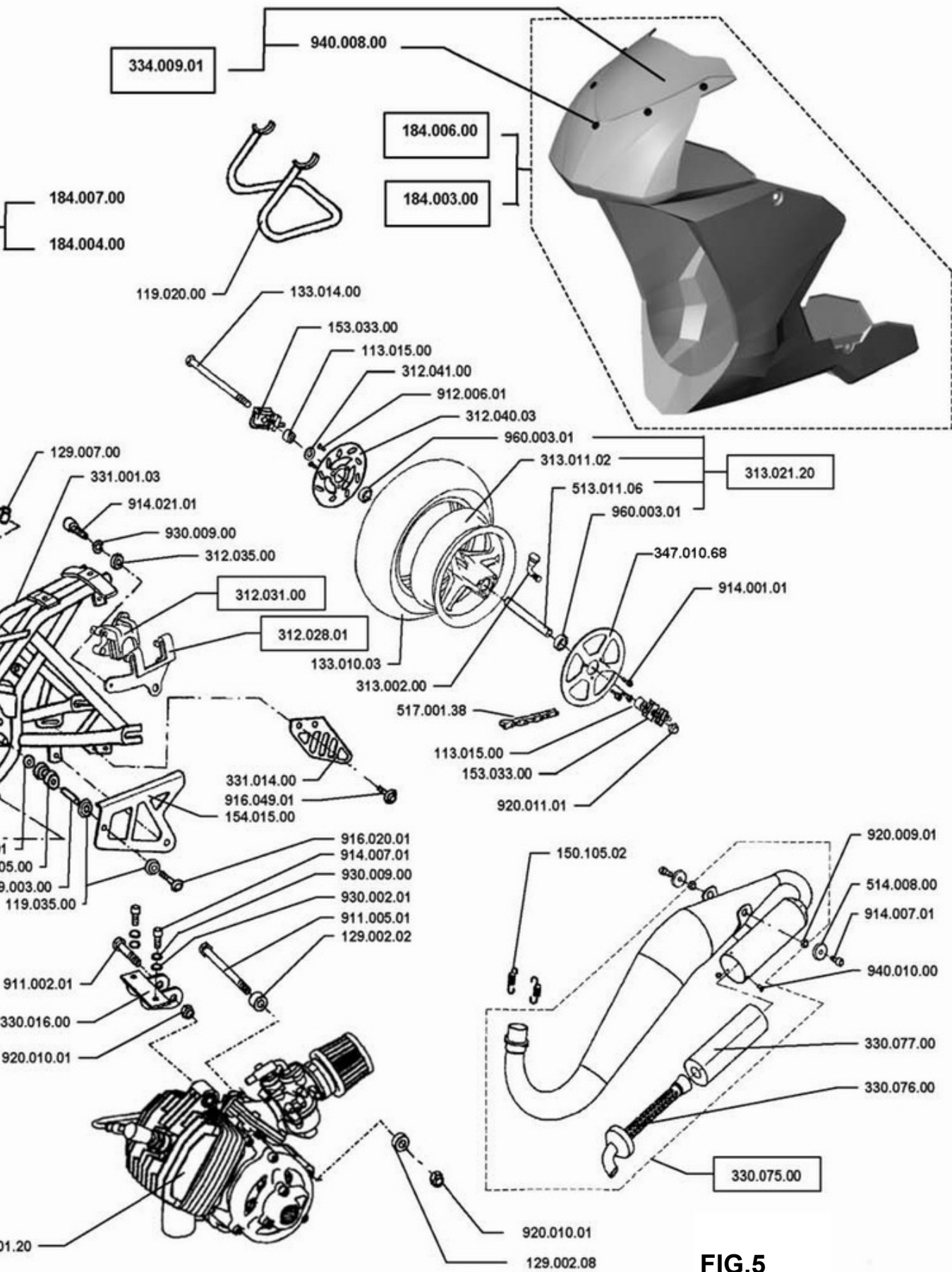

FIG.5

MINIBIKE ELITE 14 R

180.000.02	MINIBIKE ELITE 14 R	350.130.00	EXHAUST SEALING
	ENGINE	510.005.00	STARTER ROPE HAND HOLDER
120.041.00	STARTER ROPE		FRAME
150.001.20	ENGINE COMPLETE	331.001.03	FRAME VARNISHED
150.063.30	ENGINE BLOCK GASKET SET	331.014.00	SPROCKED GUARD
150.065.00	ENGINE PROPER		BRAKES
150.069.70	CYLINDER-A	122.001.00	BRAKE LEVER - LEFT
150.069.71	CYLINDER-B	122.002.00	BRAKE LEVER - RIGHT
150.069.72	CYLINDER-C	152.005.20	FRONT BRAKE PADS 160 - PAIR
150.069.73	CYLINDER-D	312.010.20	BRAKE COMPLETE - 160
150.070.30	CYLINDER+ PISTON COMPLETE	312.015.01	BRAKE CASE
150.073.30	CYLINDER HEAD COMPLETE -AIR	312.016.00	CABLE RETAINER
150.090.30	CYLINDER SEALING SET	312.017.00	LIFTER LEVER
150.105.02	EXHAUST SPRINGS-PAIR	312.018.00	MODIFIED SCREW
330.002.00	CARBURETOR PHVA 14	512.060.00	SPRING -RIGHT
330.004.00	PISTON COMPLETE -A	312.020.00	BRAKE PADS SPRING
330.004.01	PISTON COMPLETE -B	312.021.00	SPACER L=12
330.004.02	PISTON COMPLETE -C	312.025.00	REAR BRAKE PADS -PAIR
330.004.03	PISTON COMPLETE -D	312.028.01	BRAKE HOLDER COMPLETE
330.005.00	PISTON RING	312.029.00	SPRING -LEFT
330.008.00	WRIST PIN	312.030.00	BRAKE CASE
330.010.00	STARTER LEVER - CHOCKE	312.031.00	BRAKE COMPLETE
330.011.00	CRANK SHAFT	312.035.00	SPACER 6.1 x 14 x 3
330.015.00	CLUTCH SUBBASE	312.036.00	LIFTER - LEFT
330.016.00	CYLINDER HEAD HOLDER SET	312.037.00	LIFTER - RIGHT
330.017.00	CLUTCH SHOE	312.038.00	BRAKE SHAFT
330.018.01	CLUTCH CASE	312.040.03	BRAKE DISK 3 x 120
330.021.00	CLUTCH SPRING 2.5 x 6.5	312.041.00	SPACER 10.5 x 18 x 3
330.022.00	SPRING PLATE	332.001.20	FRONT BRAKE HOLDER COMPLETE 160
330.023.00	STARTER LEVER SPRING	332.003.20	BRAKE CABLE/SLEEVE ASSY
330.024.00	CLUTCH BASKET	332.018.20	BRAKE CABLE/SLEEVE ASSY
330.025.00	DISTANCE WASHER	332.020.00	BRAKE NUT
330.028.01	CLUTCH CASE	332.040.22	BRAKE DISK 3 x 160
330.029.00	PINION 6 TEETH	512.016.50	CABLE RETAINER
330.030.00	CLUTCH SHOES COMPL. (3 LEVERS)	512.019.01	WASHER
330.032.00	CLUTCH COMPLETE		WHEELS
330.039.00	SPACER - PISTON	113.015.00	SPACER L=14.5
330.040.00	STARTER COMPLETE	133.002.03	TIRE 90/65 - 6.5" T4 - SLICK
330.045.00	STARTER CASE	133.010.03	TIRE 110/50 - 6,5" T4 - SLICK
330.046.00	GROMMET	133.014.00	WHEEL AXLE
330.047.00	STARTER SPRING	153.033.00	CHAIN STRETCHER COMPLETE
330.049.00	STARTER RATCHET WHEEL	313.002.00	VALVE 90° - TUBELESS
330.051.00	SILENT BLOCK TUBE	333.005.20	WHEEL AXLE
330.052.00	INTAKE GASKET	313.010.20	RIM/HUB ASSY 2,1"- 6,5"- 99
330.053.20	INTAKE BRANCH KIT PHVA 14	313.011.02	RIM/HUB ASSY 2,3"- 6,5"-130
330.056.20	INTAKE BRANCH COMPLETE PHVA 14	313.020.20	WHEEL COMPLETE W/O TIRE 2,1"- 6,5"- 99
330.058.01	DIAPHRAGM COMPLETE KIT	313.021.02	WHEEL COMPLETE W/O TIRE 2,3"- 6,5" -130
330.059.01	DIAPHRAGM - CARBON KIT (PAIR)	513.011.04	AXLE SPACER L= 84.5
330.066.01	ENGINE BLOCK GASKET SET	513.011.05	AXLE SPACER L= 76.3
330.067.00	COIL (MAGNETO) HOLDER	513.011.06	AXLE SPACER L= 117.3
330.068.00	SPACER		BODY
330.075.00	EXHAUST COMPLETE	154.015.00	CHAIN GUARD
330.076.00	SILENCER	184.001.20	GLASS BODY COMPLETE KIT NON VARNISHED
330.077.00	SILENCER MASS	184.002.50	GLASS BODY COMPLETE KIT VARNISHED
330.078.00	CARBURETOR SEALING RING	184.003.00	FAIRING NON VARNISHED
330.080.74	JET 74	184.004.00	SEAT-TAIL ASSEMBLY NON VARNISHED
330.083.01	AIR FILTER MI - 38	184.005.00	FRONT FENDER KIT NON VARNISHED
330.085.00	BEARING CASE	184.006.00	FAIRING VARNISHED
330.089.00	JETS SET (60-90) 14 PCS	184.007.00	SEAT-TAIL ASSEMBLY VARNISHED
330.091.00	CYLINDER GASKET - 4 PCS	184.008.00	FRONT FENDER KIT VARNISHED

334.009.01	WINDSHIELD + RIVETS	913.003.01	SCREW M 8 x 35
514.008.00	RUBBER WASHER 6,5 x 23,5 x 4	914.001.01	SCREW M 5 x 16
	<u>STEERING</u>	914.003.01	SCREW M 5 x 20
515.007.00	BOWDEN DUST GUARD	914.005.01	SCREW M 5 x 30
345.100.00	CAP PE 22	914.007.01	SCREW M 6 x 16
125.001.00	HAND-GRIPS (PAIR)	914.008.01	SCREW M 6 x 20
215.006.00	THROTTLE TWIST GRIP	914.010.01	SCREW M 6 x 25
335.001.20	HANDLEBAR COMPLETE	914.011.01	SCREW M 6 x 30
125.002.00	GAS CABLE/SLEEVE ASSY	914.013.01	SCREW M 5 x 35
335.008.20	NUT	914.020.01	SCREW M 6 x 10
335.010.20	FORK WITH BRAKE HOLDER 28	914.021.01	SCREW M 6 x 12
335.011.20	RIGHT FORK 28	914.026.01	SCREW M 5 x 12
335.025.21	FORKS HOLDER ABOVE - COMPLETE (w 146)	914.035.01	SCREW M 6 x 35
335.026.21	FORKS HOLDER BELOW -COMPLETE (w 146)	914.510.01	SCREW M 6 x 30 FLAT HEAD
335.032.00	HANDLEBAR HOLDER, LEFT COMPLETE	916.005.01	SCREW M 6 x 16
335.033.00	HANDLEBAR HOLDER, RIGHT COMPLETE	916.007.02	SCREW M 5 x 12 ALLEN
335.050.20	SCREW	916.015.01	SCREW M 6 x 25
345.101.00	CAP PE 28	916.020.01	SCREW M 6 x 40
	<u>TRANSMISSION</u>	916.030.01	SCREW M 5 x 12
347.010.68	SPROCKET 68 TEETH	916.031.01	SCREW M 6 x 8
517.001.38	CHAIN 138 LINKS	916.049.01	SCREW M 5 x 6
		916.050.01	SCREW M 5 x 8
	<u>ELECTRIC COMPONENTS</u>	916.060.02	SCREW M 6 x 30 ALLEN
128.003.02	SPARK PLUG NGK B 9 EGV	916.065.02	SCREW M 5 x 25 ALLEN
158.002.00	ROTOR COMPLETE		
338.001.00	IGNITION COMPLETE	920.008.01	NUT M 5 SELF-LOCKING
338.005.00	SPARK PLUG CAP	920.009.01	NUT M 6 SELF-LOCKING
518.001.00	KILL SWITCH	920.010.01	NUT M 8 SELF-LOCKING
		920.011.01	NUT M 10 SELF-LOCKING
	<u>OTHER PARTS</u>	920.015.01	NUT M 6 WITH COLLAR
119.003.00	SPACER L=25.8	920.020.01	NUT M 8 x 1
119.005.00	CHAIN ROLLER	920.021.01	NUT M 10 x 1
119.008.00	GAS TANK WITH CAP		
119.009.00	GAS TANK W/O CAP	930.002.01	WASHER 6,4
119.010.01	GAS TANK CAP	930.003.01	WASHER 10,5
119.011.00	RUBBER FRAME PAD	930.004.01	WASHER 8,4
119.020.00	STAND	930.009.00	SPRING WASHER 6,4
119.035.00	WASHER 6.4 x 18 x 1	930.014.00	SPRING WASHER 5,4
129.002.06	SPACER L=7	930.020.01	WASHER 6,1
129.002.08	SPACER L=19		
339.006.00	FUEL HOSE 12/175	940.001.00	RIVET 4 x 8 AL
129.007.00	HOSE CLAMP 11/7 K	940.008.00	RIVET BULBEX 4.2 x 18.8 WITH CAP
129.008.00	HOSE CLAMP 12/8 J	940.006.00	CYLINDER 6x6
129.009.00	HOSE CLAMP 10/7 H	940.010.00	RIVET 4x8 STEEL
129.017.00	WASHER 6.4 x 16 x 1	950.003.00	WOODRUFF KEY 3e7 x 3,8
139.001.02	ADJUSTABLE FOOT REST -RIGHT	950.008.00	SAFETY LOCK 35
139.001.03	ADJUSTABLE FOOT REST -LEFT	950.009.00	SAFETY LOCK 17
139.010.01	ADJUSTABLE FOOT RESTS -PAIR	950.018.00	SAFETY LOCK 10 x 1
189.002.00	DECAL SET - ELITE14	950.025.00	SAFETY LOCK 6
189.004.00	SADDLE RUBER, COMPLETE	950.050.00	SPRING PIN 10 x 50
329.001.01	FOOT PEGS PLASTIC -PAIR		
339.010.20	FUEL HOSE 10/150	960.003.01	BALL BEARING 6000 - VVCM NS 7S
339.012.00	HOSE CLAMP 28/8 L	960.004.00	BALL BEARING 6200 - 2 ZR
339.012.01	HOSE CLAMP 8/7 M	960.009.01	BALL BEARING 6003 - 2 ZR
349.027.00	FUEL COCK	960.012.00	BALL BEARING 626
519.024.00	WASHER 6.4 x 18 x 1.5	960.015.01	BALL BEARING 6203 TN 9 C3
	<u>OTHER HARDWARE</u>	960.106.00	NEEDLE BEARING 10 x 14 x 12,8
911.002.01	SCREW M 8 x 45	970.005.00	SEAL 17 x 25 x 4
911.005.01	SCREW M 8 x 110	971.050.00	O - RING 5 x 1,8
911.007.01	SCREW M 10 x 140		
912.006.01	SCREW M 5 x 16	971.080.00	O - RING 41 x 1,78

ENGINE COMPLETE 150.001.20

FIG. 10

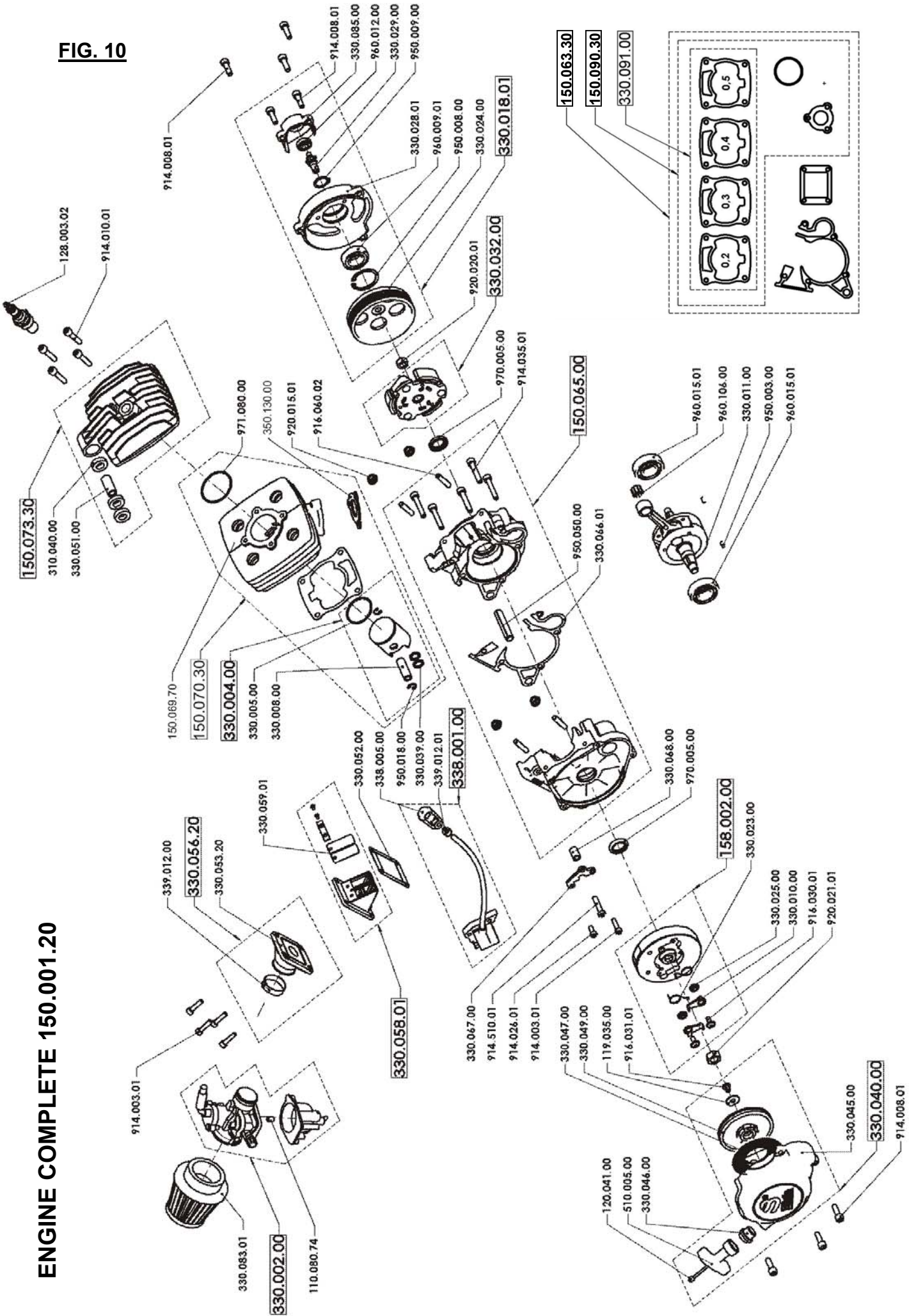

FIG. 6

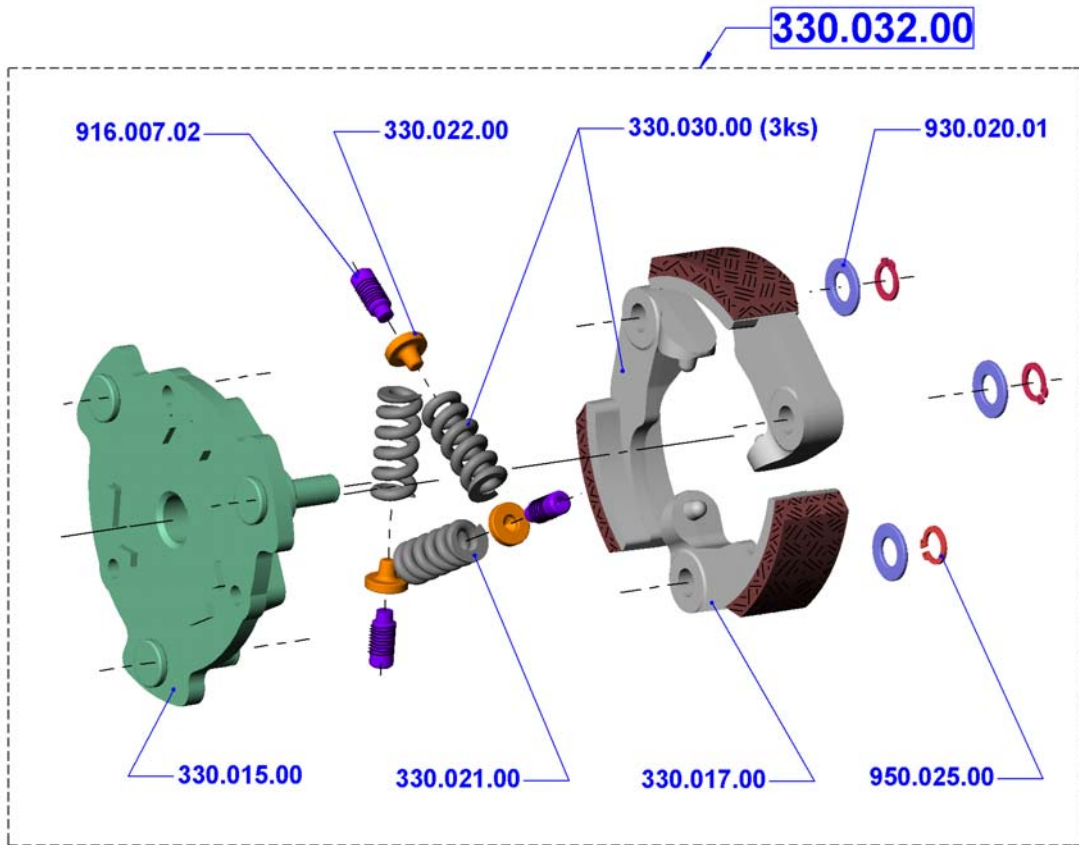

FIG. 16

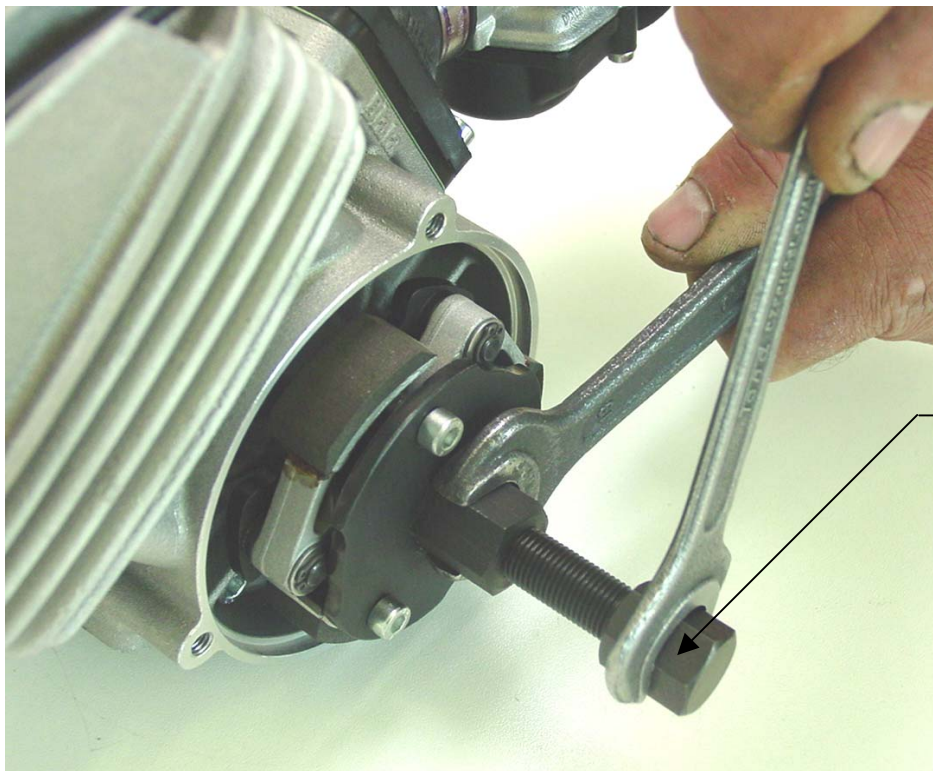
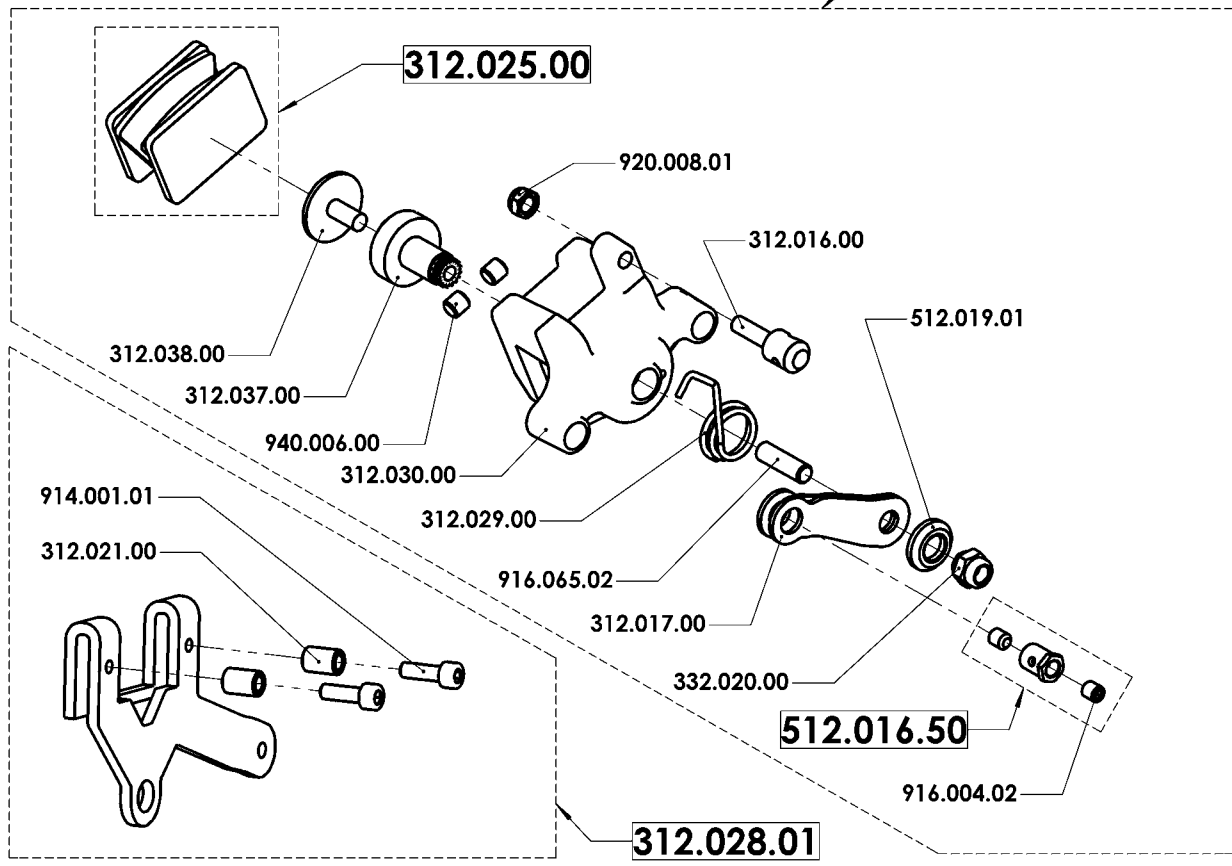
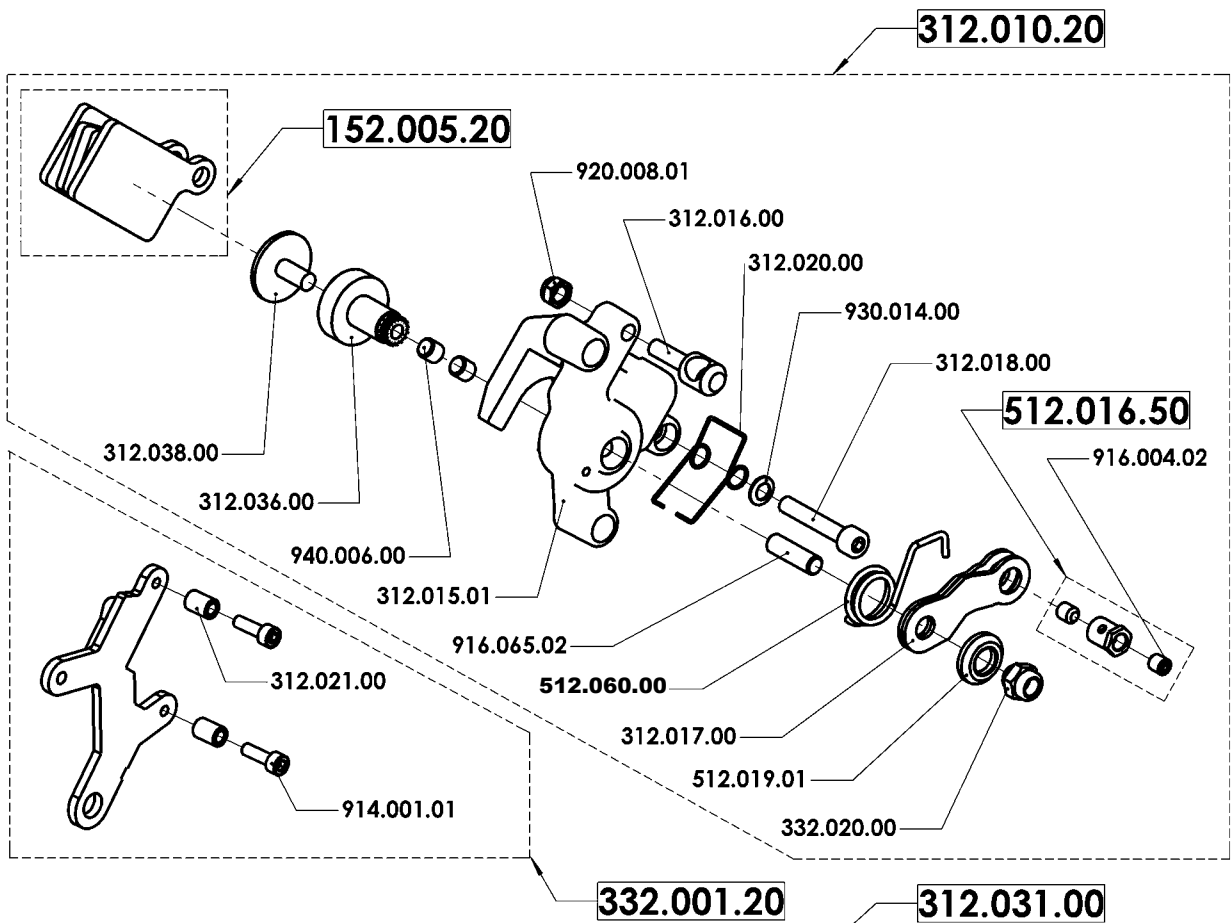

FIG. 7



REMOVE AND REPLACE THE FRONT WHEEL - FIG. 5

Before dismantling the front wheel it is necessary to remove the front brake pads from the front brake, so it is possible to move the brake caliper from the wheel and be able to draw out the wheel and tire. Remove the front axel nut M10 (920.011.01) .Draw out the axel from the fork and wheel. Remove the wheel by an easy pull downwards from the forks. Caution, while removing the wheel the left side spacer washer will fall out! During the assembly process put the spacer washer between the brake rotor and brake caliper mount plate and the right side distance spacer between the wheel and right fork (315.011.00). Return the brake pads with the spring and tighten up the axel nut. Perform the basic brake adjusting. **Double check your work. This is important!**

REMOVE AND REPLACE THE REAR WHEEL - FIG. 5

Remove the rear wheel axel nut. Loosen the nut on the rear caliper anchor plate. Remove the two wheel adjustor plate nuts. (M6) Move the wheel forward and remove the chain. Safely (hold) keep the rear wheel from falling out while pulling out the axel. Caution, note the location of both spacer tubes and one spacer washer (between caliper mount plate and rotor) while removing wheel. When refitting the wheel, make sure to slide the brake rotor into the caliper between the pads. Hold the wheel in place and fit the wheel spacers in proper order. Insert the spacer washer between the caliper plate and the brake rotor and on the both sides place the axel spacers at the appropriate time during assembly. Adjust chain tension and tighten axel nut. Tighten the caliper holder plate nut and set and tighten both chain adjustor plate M6 nuts. At this time check the brake operation. **Recheck all your work. This is important!**

REPLACEMENT OF PINION - FIG. 9

First dismantle the front chain guard and chain guard.Loosen the nut of rear wheel axle and the nut of chain tightener ,remove chain. Insert carefully a larger screw drive or steel rod into the hole of clutch drum, Fig. 9, to avoid a turning over the clutch drum at releasing the pinion. Using the pinion wrench P/ N 319.050.00, release the new pinion to be carried out by reverse way.

FIG. 9

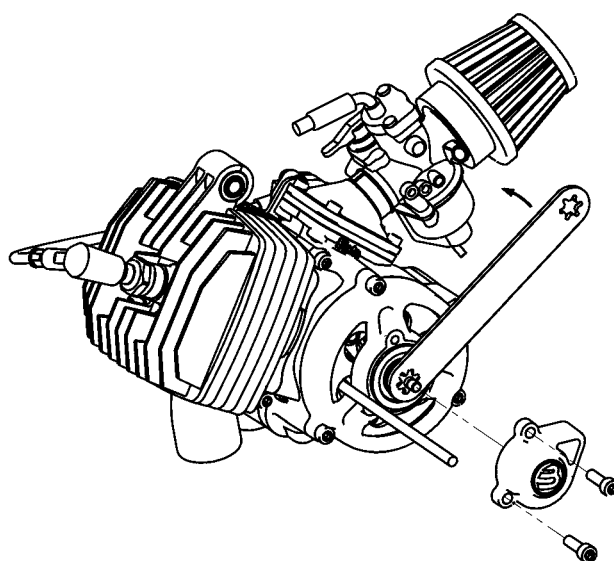

REPLACEMENT OF TIRE – FIG. 5

Remove the wheel from the minibike. For the front wheel unbolt the brake disk and for the rear wheel, the brake disk and sprocket. Deflate the tire, by removing the valve stem. Place the wheel on a hard surface and press the tire bead from the wheel rim in to the middle relief at centre of rim. Tire is ready to be removed from the rim at this time and is done in the conventional manner. After fitting new Tire and Tube (if necessary) to the rim, you can inflate 28 to 30 psi. Take care to check that the tire bead is fully seated in the rim bead edge. You can now refit the wheel to the bike in reverse order to removing it. Use Caution and recheck your work always.

DISMANTLING AND MOUNTING OF AIR FILTER - FIG. 3

Remove the bolt from the sleeve, which connects the rubber holder of the air filter to the carburetor. When the air filter is loosened, take it out and very carefully wash it in air drying solvent, lubricate it when dry and spray with air filter oil and reassemble, following the steps in the reverse order.

CLUTCH ADJUSTMENT – FIG. 8

After first hour of use, check the state of the clutch pads. Review the clutch adjustment – engaged with 8 000 – 8 500 rpm.

Basic adjusting:

After every clutch slipper shoe replacement it is necessary to adjust the clutch springs. To increase the revolutions, and feel the clutch working, tighten up the adjusting bolts and to engage shoes at lower revolutions, loosen the bolt. It is important to adjust all the springs to the same level, so the clutch lining wearing is even. The index for adjusting is the length of the spring, which should be 21,00 mm. The length is measured from the bearing surface of the clutch shoe to the spring plate.

FIG. 8

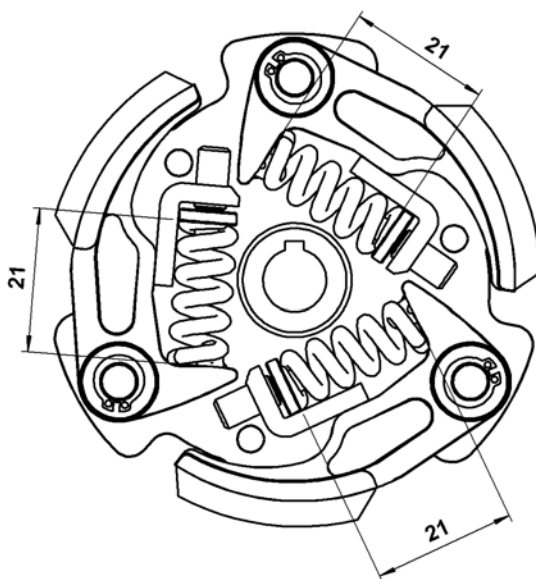

TORQUE SETTINGS

(1 FT-LB = 1.3558 Nm)

PART NAME	QTY	TORQUE SETTING (FT-LB)	SECURED BY
ENGINE			
Cylinder head, liquid cooled – M6	6	14	
Cylinder – nuts M6	4	13	
Intake manifold – M5	4	7	
Starter cover – M6	3	15	
Ratchet wheel –bolt M6	1	13	Loctite 243
Magneto (rotor) – nut M10	1	34	
Starter prowl – bolts M5	2	7.5	Loctite 243
Ignition coil – bolts	2	7.5	
Ignition coil holder – bolt M6	1	11	
Crankcase halves – M6	5	21	
Clutch base – nut M8	1	30	Loctite 243
Clutch case – bolts M6	3	14	
Pinion bearing case – bolts M6	2	14	
Reeds - bolts M3	4	1	Loctite 243
Float chamber – bolts M4	2	3	
Slider cover (carburetor) – bolts M4	2	3	
Fuel filter cap – bolt M5	1	3.5	
Pinion - M8	1	30	Loctite 243
FRAME			
Front wheel axle - nut M10	1	47.5	Self - locking
Front brake rotor – M5	3	20.5	
Front brake bracket – M6	2	17	Loctite 243
Brake mount –M5	2	13	Loctite 243
Steering shaft – M10	1	27	Self - locking
Handlebar clip-on –M8	2	25	
Fork brackets – M5	4	12	
Steering stem – M6	2	24.5	
Engine bracket, top –M6	2	20.5	
Engine bracket, head – M8	1	25	Self - locking
Engine bracket, bottom – M8	1	30	Self - locking
Rear wheel axle – nut M10	1	47.5	Self - locking
Rear brake rotor – M5	3	20.5	
Sprocket – M5	3	20.5	
Foot rests – M8	2	27	Self - locking
Chain guard –M6	1	21	
Sprocket guard – M5	1	14	
Rear brake holder –M5	2	13	Loctite 243
Expansion chamber – M6	2	7	Self - locking
Fairing, seat and rear fender – M6	9	8	
Rear caliper anchor plate –M6	1	17	
Handlebar clips – M6	2	11	
Brake levers clips – M5	2	5	
Throttle clip (handlebar) – M5	2	7	
Throttle plastic cover – M4	2	3	

NON USE AND STORAGE PROCEDURE

It is recommended to drain out all fuel from the tank and carburetor. Inflate the tires to the working pressure and put the minibike on the stand. During a *long storage period, unbolt the spark plug and insert a couple of drops of the motor oil into the cylinder. Pull the starting rope a couple of times so a film of oil covers and evenly coats the cylinder walls and piston rings.

* Long period is 90 days and longer.

Rights reserved for technical, text and design changes of the BLATA Company.

It is a great honor for us, that you have chosen our product. We believe that the MINIBIKE will work for you without problems and will bring you much pleasure and fun.

The producer of the MINIBIKE is BLATA Company.

Manufacturing Number CZ

Signature of the technical control:

This manual served also as a GUARANTEE LIST. Please, after receiving the product check the manufacturing number and the date of sale. In the case of a claim it is necessary to submit this guarantee list.

Rights of a purchaser governed by special legislation relating to the purchase of goods are not violated by granting the warranty.

Date, stamp and signature of the dealer: